

# Artificial Hand for Disabled using Eye Ball Movement

C. Praveen kumar<sup>1</sup>, C.N. Divya<sup>2</sup>, P. Gautham<sup>3</sup>

PG Scholar, Dept. of EIE, Valliammai Engineering College, Chennai, India<sup>1,2,3</sup>

**Abstract:** The human hand is a very vital organ in our body that can grasp tools of different sizes and shapes. Nowadays many research activities are carried out to develop artificial hands with capabilities similar to that of human hand. In this paper the design and function of a new humanoid-type hand similar to that of human hand manipulation abilities is discussed. This artificial hand is made to operate with a sensor which senses the eye ball movement and operates the artificial hand. The new hand is designed to work autonomously or interactively in coordination with humans and for an artificial lightweight arm for handicapped persons. The arm is developed similar to the human arm and is driven by spherical ultrasonic motors. The ideal end-effector for such a humanoid would be able to use the tools and objects that a person uses when working in the same environment. A new hand is designed for anatomical consistency with the human hand which includes the number of fingers, placement and motion of the thumb, the proportions of the link lengths and the shape of the palm. It can also perform most part of human grasping types.

**Keywords:** Humanoid, L293D

## I. CIRCUIT OVERVIEW

The device consists of power supply section, eye ball sensor, PIC micro controller 16F877A, motor driver IC, LCD display, brushless DC motors which are placed for robot movements in the upward, downward and picking an object movement of the robot.

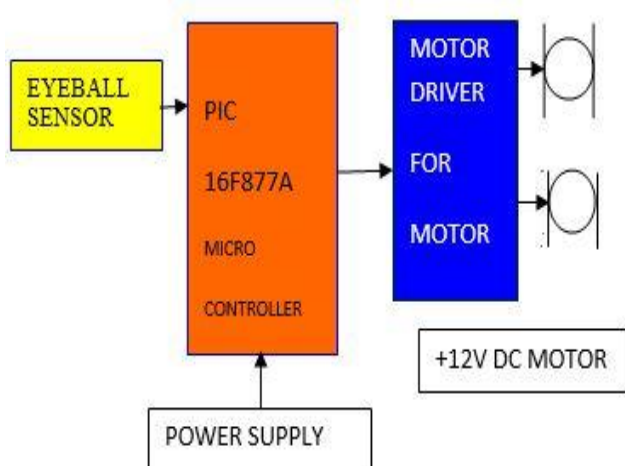

Figure 1. Block diagram

The block diagram of the entire setup is shown in the figure 1. From the eyeball sensor the analog voltage comes to I/O port A of micro controller. Eight output pins from the port B are connected to the LCD display.

The overall circuit diagram is shown in the figure 2. The motor driver IC is connected from port D of the microcontroller. The L293D motor driver IC is used for driving inductive loads like motors and relays. The embedded product development life cycle is shown in figure 3. This life cycle chart gives an overview about the requirements/ demand of an instrument/ device and the procedures involved in its manufacturing.

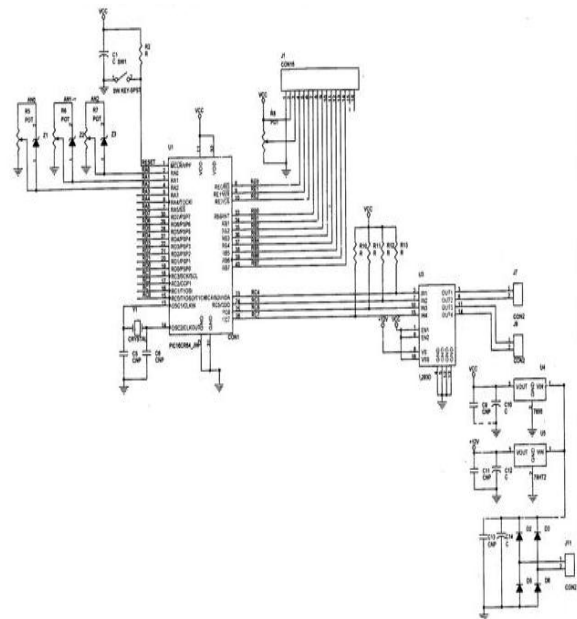

Figure 2. Circuit diagram

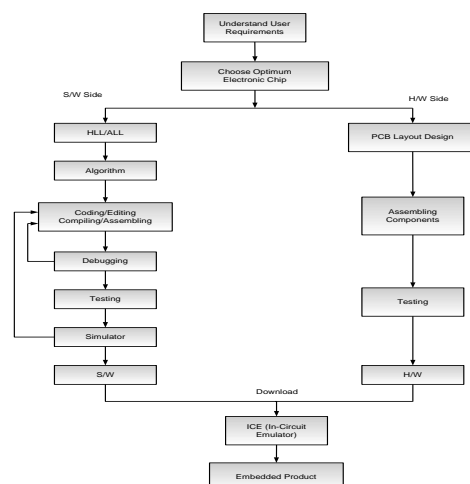

Figure.3 Embedded Product Development Life Cycle

## II. OPERATION OF BLOCKS:

### A. POWER SUPPLY

The AC voltage of 220V, is connected to a transformer. A rectifier i.e. diode, then provides a full-wave rectified voltage which is filtered by a simple capacitor filter to produce a dc voltage which has some ripple or ac voltage variation.

These ripples are removed by the regulator circuit which will maintain the same dc value even if the input dc voltage varies, or the load connected to the output dc voltage changes. Using one of the popular voltage regulator IC units these voltage regulations are usually obtained.

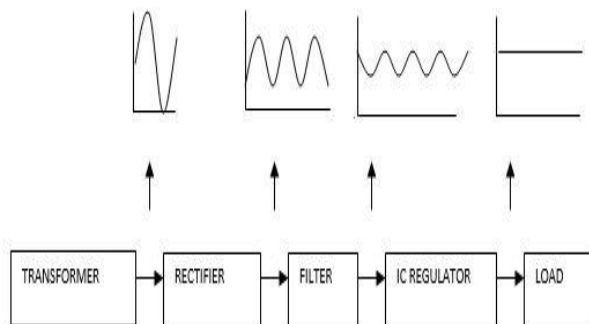

Figure.4 Block Diagram of Power supply

### Working principle Transformer

The power supply voltage is step downed from (0-230V) to (0-6V) level by a potential transformer. A precision rectifier is connected to the secondary of the potential transformer, which is made of op-amp. The precision rectifier is used here because of its advantages. The precision rectifier will give peak voltage output as DC whereas the rest of the circuits will give only RMS output.

### Bridge rectifier

The four diodes are connected to form a bridge rectifier. The input is applied to the diagonally opposite corners of the network, and from the remaining two corners the output is taken.

Here let us assume that the transformer is working properly with a positive potential and a negative potential at points A and B respectively. The positive potential at point A will forward bias diode D3 and reverse bias the diode D4.

The diodes D1 and D2 are forward biased and reverse biased at the point B because of the negative potential. At this time the diodes D3 and D1 are forward biased and it will allow current flow to pass through them and diode D4 and D2 are reverse biased and they will block the current flow.

The path for current flow is from point B through D1, up through RL, through D3; through the secondary of the transformer back to point B. this path is indicated by the solid arrows. Waveforms (1) and (2) can be observed across D1 and D3.

One-half cycle later the transformer's polarity across the secondary reverses, forward biasing the diodes D2 and D4 and reverse biasing the diodes D1 and D3. Now the current flow will be from the point A through diode D4, up through RL, through D2, through the secondary of T1, and back to point A. This path is indicated by the broken arrows. Waveforms (3) and (4) can be observed across D2 and D4. The current flow through RL is always in the same direction. In flowing through RL this current develops a voltage corresponding to that shown waveform (5). Since current flows through the load (RL) during both half cycles of the applied voltage, this bridge rectifier is a full-wave rectifier.

### IC regulators (voltage regulators)

The voltage regulators comprise of a class of widely used ICs. Regulator IC units will consist of the circuitry for reference source, comparator amplifier, control device, and the overload protection. They are all fixed in a single IC. IC units provide regulation of either a fixed positive voltage, a fixed negative voltage, or an adjustable set voltage. The regulators can be selected for operation with load currents

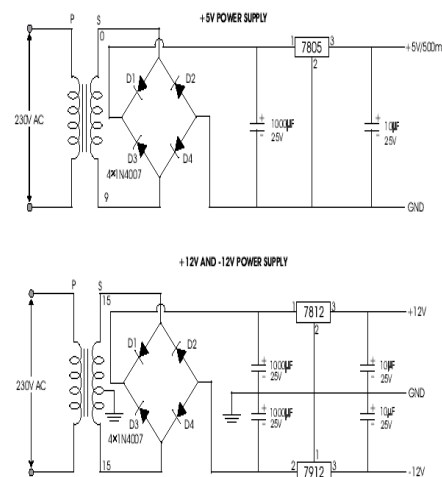

from hundreds of mille amperes to tens of amperes, corresponding to the power ratings from mille watts to tens of watts.

Figure.5 Circuit Diagram of Power Supply

A fixed three-terminal voltage regulator has an unregulated dc input voltage  $V_i$ , this voltage is applied to one input terminal, a regulated dc output voltage  $V_o$ , from a second terminal, with the third terminal connected to ground. The series 78 regulators provide fixed positive regulated voltages from 5 to 24 volts. Similarly, the series 79 regulators provide fixed negative regulated voltages from 5 to 24 volts.

- For ICs, microcontroller, LCD - 5 volts
- For sensor, motors - 12 volts

### B. MICROCONTROLLER

PIC16F877A microcontroller is used for this paper work. The features of microcontroller are as follows.

It is 8-bit Microcontroller, System is RISC Architecture, It has Small set of Instruction set and has 35-Instructions only. Compatibility: avail 28/40 Pin ICs

**Microcontroller overview**

✓ Operating Speed Max 20 MHz, Voltage-(2-5.5)v  
Memory: Flash Program - 8Kx14 Words,  
RAM - 368 Bytes, EEPROM Data Memory - 256 Bytes,  
Low power, High speed Flash/EEPROM Technology

**DESCRIPTION:**

The 16F877A is one of the most popular PIC microcontrollers and it comes in a 40 pin DIP pin out and it has many internal peripherals. The 40 pins make it easier to use the peripherals as the functions are spread out over the pins. This makes it easier to decide what external devices to attach without worrying too much if there enough pins to do the job. One of the main advantages is that each pin is only shared between two or three function.

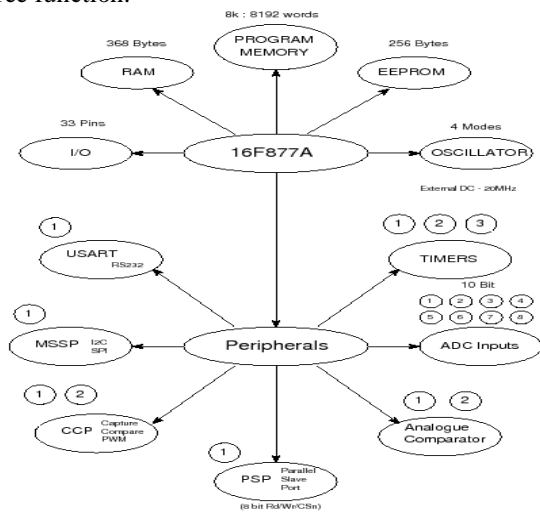

Figure.6 PIC16F877A

**C. MOTOR DRIVER IC L293D:**

The features and description of motor driver L293D are as follows.

**FEATURES OF L293D**

- It has a wide Supply-Voltage Range of about 4.5 V to 36 V. It also has a separate Input-Logic Supply.
- It has Internal ESD Protection and Thermal Shutdown.
- It has a very High-Noise-Immunity Inputs.
- Functional Replacements for SGS L293 and SGS L293D.
- It's Output Current is 1 A Per Channel (600 mA for L293D)
- It's Peak Output Current is 2 A Per Channel (1.2 A for L293D)
- It has Output Clamp Diodes for Inductive Transient Suppression (L293D).

**DESCRIPTION:**

The driver IC's L293 and L293D are quadruple high-current half-H drivers. The L293 driver is designed to provide bidirectional drive currents. This driver current ranges up to 1 A at voltages from 4.5 V to 36 V. Whereas the driver L293D is designed to provide bidirectional drive currents. This driver current ranges up to 600-mA for the voltages from 4.5 V to 36 V.

Both the drivers L293 and L293D are designed to drive inductive loads such as relays, solenoids, dc and bipolar stepping motors, as well as other high-current/high-voltage loads in positive-supply applications. All inputs are TTL compatible. Each output is a complete totem-pole drive circuit and each output has a Darlington transistor sink and a pseudo-Darlington source. These drivers are enabled in pairs, as the drivers 1 and 2 are enabled by 1,2EN and drivers 3 and 4 are enabled by 3,4EN. When an enable input is high, the associated drivers are enabled and their outputs are active and they are also in phase with their inputs.

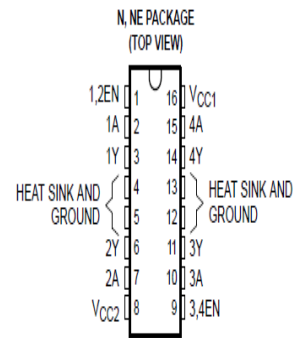

Figure.7 Pin Diagram OF L293D IC

It is stated above that the motor driver IC consists of two Darlington pairs. The Darlington transistor are often called a Darlington pair. These Darlington transistors are a compound structure consisting of two bipolar transistors (either integrated or separated devices) connected in such a way that the current amplified by the first transistor is amplified further by the second one. This configuration gives much higher current gain than each transistor taken separately whereas in the case of integrated devices, it can take less space than two individual transistors because they can use a shared collector.

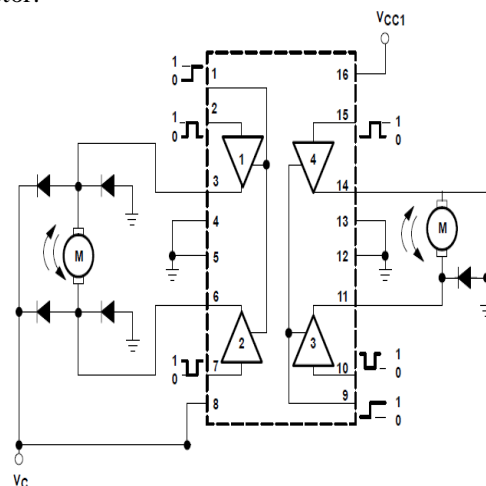

Figure.8 Circuit Diagram of Motor Driver IC

**D. LCD:**  
**Display Unit:**

This Display section explains the LCDs operating modes along with the procedures of how to program and interface an LCD with a PIC Microcontroller.

**LCD Operation:**

In recent years the LCD is finding widespread use replacing LEDs (seven-segment LEDs or other multi segment LEDs). This is due to the following reasons:  
The price of LCDs are declining.  
The ability to display numbers, characters, and graphics. This is in contrast to LEDs, which are limited to numbers and a few characters.  
Incorporation of a refreshing controller into the LCD, thereby relieving the CPU of the task of refreshing the LCD. In contrast, the LED must be refreshed by the CPU (or in some other way) to keep displaying the data.  
Ease of programming for characters and graphics.

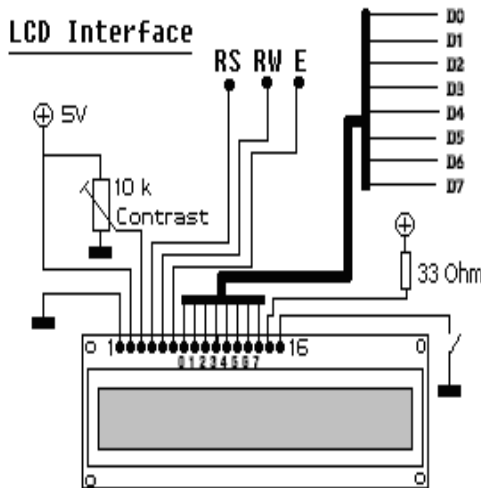

Figure.9 LCD Interfaced with Microcontroller

**LCD pin descriptions:**

The 14 pins LCD is discussed in this section. The functions of those pins are given below.

**V<sub>CC</sub>, V<sub>SS</sub> and V<sub>EE</sub>:**

The V<sub>CC</sub> and V<sub>SS</sub> pins are connected to +5V and upon the eyeball movement. If the eyeball moves left ground respectively. The V<sub>EE</sub> pin is used for the purpose of controlling LCD contrast.

**RS, Register Select:**

Two very important registers are there inside the LCD. The RS pin is used for their selection as follows.

If RS=0, the instruction command code register is selected which allows the user to send a command. Some of the commands are clear display, cursor at home, etc.  
If RS=1, the data register is selected which allows the user to send data to be displayed on the LCD.

**R/W, Read/Write:**

R/W input will allow the user to write some information to the LCD or read information from LCD. R/W is assigned as 1 for reading and R/W is assigned as 0 for writing.

**E, Enable:**

For the LCD to latch the information presented to its data pins the enable pin is used. When data is supplied to data pins, a high-to-low pulse must be applied to this enable pin for the LCD to latch in the data presented at the data pins. This pulse must be a minimum of 450ns wide.

**D0-D7:**

The pins from D0-D7 are 8-bit data pins. These pins are used to send information to the LCD and also to read the contents of the LCD's internal registers.

For the purpose of displaying letters and numbers, we send ASCII codes for the letters A-Z, a-z, and numbers 0-9 to these pins while making RS=1.

There are also instruction command codes that can be sent to the LCD to clear the display or force the cursor to the home position or blink the cursor.

To check the busy flag bit and to see if the LCD is ready to receive the information the RS bit is assigned to 0. The D7 is the busy flag and can be read when R/W=1 and RS as 0. This is stated as follows: if R/W=1, RS=0. When D7=1 (busy flag=1), the LCD is busy taking care of internal operations and will not accept any new information.

**III. CONCLUSION**

EyeBall sensor is issued to control the movement of robot. Two motors are used. One of the motor is attached to the elbow for upward and downward movement of hand. Other motor is attached to the finger for picking up and down of objects. PIC 16F877A micro controller is used. To control the hand movement motor driver IC L293D is used. The sensor is attached to the eyeball. Retina produces some voltage, with the help of voltage driver it's controlled. The circuit diagram is shown in the figure.10. The voltage produced depends on the side of the eyeball. If the eyeball moves left side, some voltage is produced and due to this motor elbow is rotated in clockwise direction and the hand will be moving downwards. If it is in right side, rotation takes place vice versa. If the eyeball moves upward side, some voltage is produced and due to this motor rotates and the finger opens and if the eyeball moves downward rotation takes place vice versa in motor and finger is closing.



Figure.10 Circuit diagram of entire setup



control, Industrial Instrumentation and Control system.



**C.N.Divya** received her B.E., Electronics and Instrumentation, from Mahendra Engineering College in 2013. Currently she's pursuing M.E., Control and Instrumentation from Valliammai Engineering College. His area of interests includes Control system, Circuit Theory, Robotics



**P.Gautham** received his B.E., Electrical and Electronics, from SKP Engineering College in 2012. Currently he's pursuing M.E., Control and Instrumentation from Valliammai Engineering College. His area of interests includes Power Electronics, Electrical Instruments and Control system.

### REFERENCES

- 1) Rafael Barea, Luciano Boquete, Manuel Mazo, "System for Assisted Mobility Using Eye Movements Based on Electrooculography," IEEE transactions on neural systems and rehabilitation engineering, vol. 10, no. 4, December 2002
- 2) C. Fraser and A. W. Wing, "A case study of reaching by a user of a manually-operated artificial hand", *Prosthetics and Orthotics International*, 1981, 5, 151-156
- 3) R. J. K. Jacob, *Eye Movement-Based Human-Computer Interaction Techniques: Toward Non command Interfaces*. Wash., D.C.: Human-Computer Interaction Lab. Naval Res. Lab., 1995.
- 4) ERICA Project, "Eyegaze response interface computer aid system," ERICA Inc.
- 5) G. Evans, R. Drew, and P. Blenkhorn, "Controlling mouse pointer position using an infrared head-operated joystick," *IEEE Trans. Rehab. Eng.*, vol. 8, Mar. 2000.
- 6) W. North, "Accuracy and precision of electrooculographic recording," *Invest. Ophthalmol.*, vol. 4, pp. 343-348, 1965.
- 7) J. A. Lahoud and D. Cleveland, "The eyegaze eyetracking system," in *LC Technologies, Inc. 4th Ann. IEEE Dual-Use Technol. Applicat. Conf.*, NY.
- 8) L. Ferman, H. Collewijn, T. C. Jansen, and A. V. van den Berg, "Human gaze stability in the horizontal, vertical and torsional direction during voluntary head movements, evaluated with a three dimensional scleral induction coil technique," *Vision Res.*, vol. 27, pp. 811-828, 1987.
- 9) J. Glenstrup and T. Engell, "Eye Controlled Media: Present and Future State," PhD, DIKU (Institute of Computer Science) Univ. Copenhagen, Denmark, 1995.

### BIOGRAPHIES



**C.Praveen kumar** received his B.E., Electronics and Instrumentation, from Annamalai University in 2013. Currently he's pursuing M.E., Control and Instrumentation from Valliammai Engineering College. He has delivered many seminars on his YouTube channel. His area of interests includes Process